

Zenox High Head Submersible Drainage Pump



- High performance, two-stage strainer pump for high head applications
- Building site dewatering
- Feeding drippers from treatment chambers
- Stormwater drainage where greater head is required

Two Models Available:

ZHS-040-1A 240 volt, 0.40 kW, Automatic

ZHS-075-1A 240 volt, 0.75 kW, Automatic

FEATURES:

- Stainless steel/cast iron construction
- Double mechanical seal lubricated in oil chamber
- Will pass solids up to 8 mm
- Thermally protected motor

- 32/40 mm vertical discharge
- 10 metre cable H07 RN-F

PUMP PERFORMANCE:

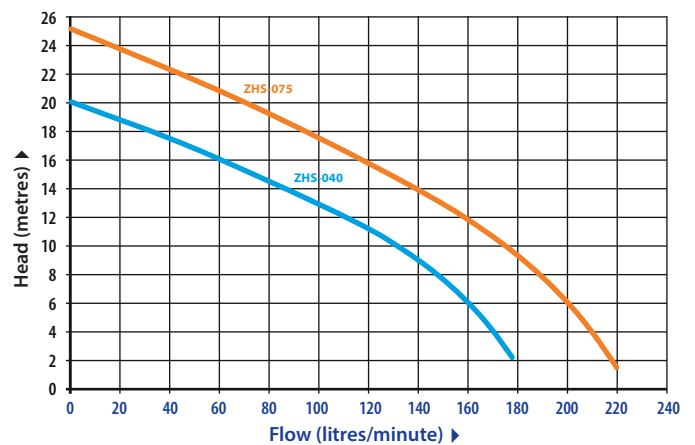

SPECIFICATION:

Model Name	Maximum Flow rate	Maximum Head	Motor Size	Weight	Dimensions W x D x H
ZHS-040	180 L/min	20	0.40kW	16 kg	227 x 151 x 370
ZHS-075	220 L/min	25	0.75kW	17 kg	245 x 170 x 474

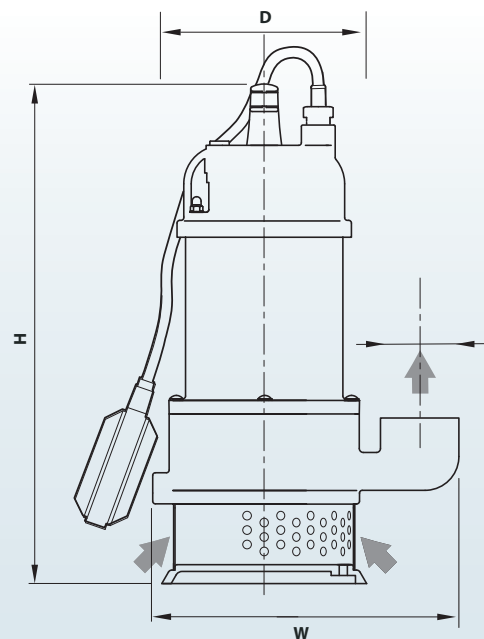

Zenox Pumps

Zenox Pumps reserves the right to change product specifications

