

WATER SUPPLY & PRESSURE PUMPS

Centrifugal Pumps

SE SERIES



EURO RANGE

APPLICATION

Centrifugal pumps that combine medium head with medium-high delivery; ideal for sprinkle irrigation and in applications where quiet operations are requested and only slight pressure change as the delivery changes.

CONSTRUCTION FEATURES

Pump body	Cast iron
Motor bracket	Cast iron
Impeller	Brass
Mechanical seal	Ceramic-graphite
Motor shaft	Stainless steel AISI 303
Liquid temperature	0 - 90 °C
Operating pressure	Max 6 bar

MOTOR

2 Pole induction motor	1~ 240V-50Hz With thermal protection
Insulation class	F
Protection degree	IP44

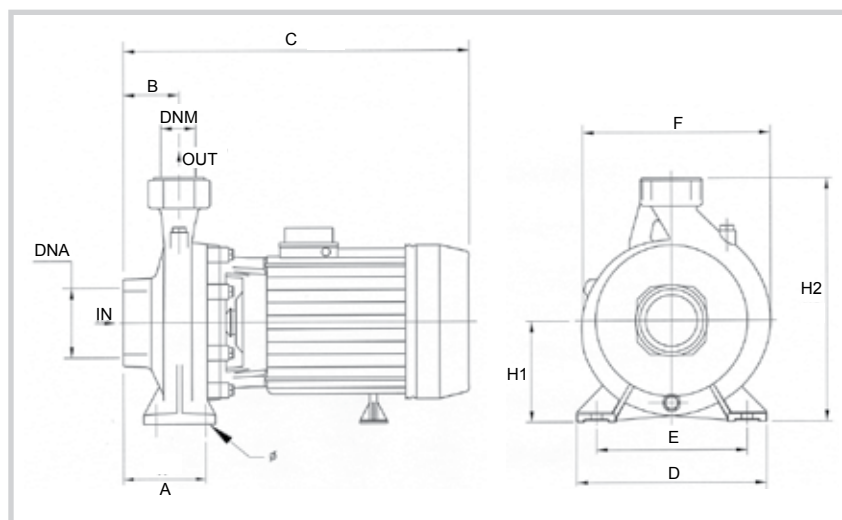

TECHNICAL DATA

Type		P2		P1 (kW)		Ampere		Q (m ³ /h - l/min)								
1~	3~	(HP)	(kW)	1~	3~	1~	3~	0	6	9	12	15	18	21	24	27
						50 Hz	50 Hz	0	100	150	200	250	300	350	400	450
								H (m)								
SE160	SE160T	1.5	1.1	1.8	1.8	8.3	3.4	24.5	23.9	22.9	21.4	19.5	17.3	14.7	11.6	7.8
SE210	-	2	1.5	2.1	-	10.1	-	26.3	25.9	25.0	23.6	21.7	19.6	17.1	14.1	10.6

rpm / 1':



2900/ 3450

Rev.:

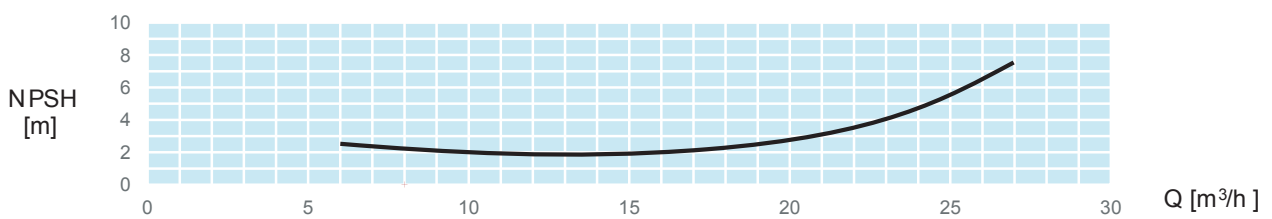
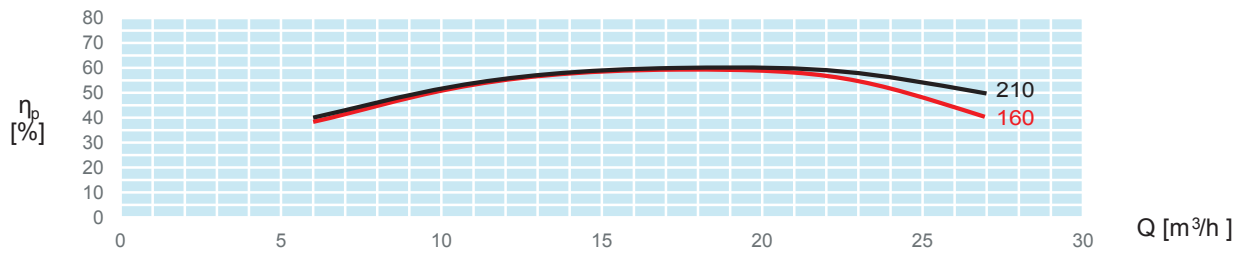
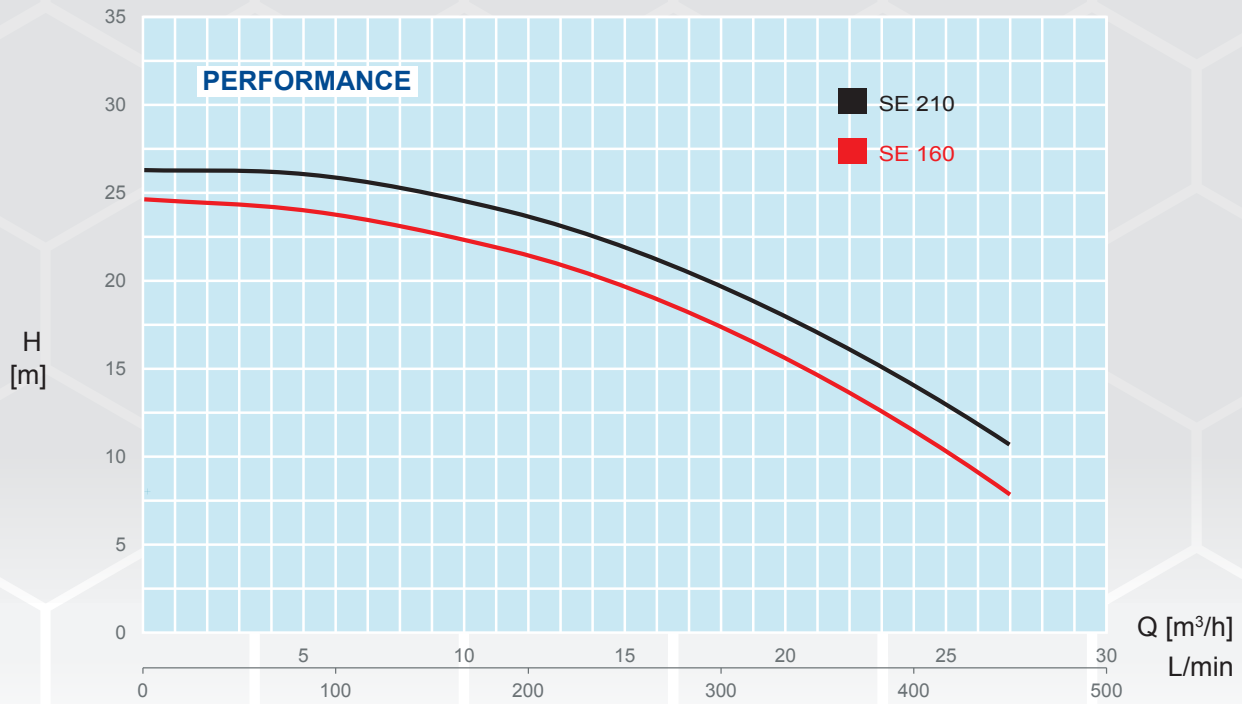
1



DIMENSIONS

Type	Dimensions (mm)														 Kg
	A	B	C	D	E	F	ø	H1	H2	DNA	DNM	I	L	M	
SE160	105	48	370	200	160	215	9.5	110	280	2"G	2"G	390	230	300	22
SE210	105	48	370	200	160	215	9.5	110	280	2"G	2"G	390	230	300	24

MODEL RANGE

Code	Description
SE160-1	HYJET 1.1 KW 240V 90 L/min Cast Iron Shallow Well Pump with 2.5m Cable and 3 Pin Plug
SE210-1	HYJET 1.5 KW 240V 120 L/min Cast Iron Shallow Well Pump with 2.5m Cable and 3 Pin Plug