

## Submersible pumps

-  Sewage water
-  Domestic use
-  Civil use
-  Industrial use



### PERFORMANCE RANGE

- Flow rate up to **1600 l/min** (96 m<sup>3</sup>/h)
- Head up to **25 m**

### APPLICATION LIMITS

- **10 m** maximum immersion depth (with a sufficiently long power cable)
- Maximum liquid temperature **+40 °C**
- Passage of solids:
  - up to **Ø 50 mm** for MC /50
  - up to **Ø 70 mm** for MC /70
- Minimum immersion depth for continuous service:
  - **390 mm** for MC /50
  - **430 mm** for MC /70

### CONSTRUCTION AND SAFETY STANDARDS

- **10 m** long power cable
- External float switch and control box for single-phase versions

EN 60335-1  
IEC 60335-1  
CEI 61-150

EN 60034-1  
IEC 60034-1  
CEI 2-3



### CERTIFICATIONS

Company with management system certified DNV  
ISO 9001: QUALITY



### INSTALLATION AND USE

**MC** series pumps, made from heavy gauge robust cast iron, resistant to abrasion and long-lasting, are fitted with a DOUBLE-CHANNEL impeller and are capable of pumping liquids containing short fibred suspended solids. They are ideal for pumping **sewage, waste water, water mixed with mud, groundwater and surface water** in locations such as blocks of flats, public buildings, factories, multi-storey and underground car parks, washing areas, etc.

### PATENTS - TRADE MARKS - MODELS

- Patent n. IT0001428923
- Registered EU Design n. 342159-0017

### OPTIONS AVAILABLE ON REQUEST

- **QES** control box for three-phase pumps
- Single-phase pumps without float switch
- Other voltages or 60 Hz frequency

### GUARANTEE

**For the following versions the incorporated thermal overload protector must be connected to the control box for the guarantee to be considered valid:**

- |                    |                            |
|--------------------|----------------------------|
| single-phase       | three-phase                |
| – <b>MCm 30/50</b> | – <b>MC 15-20-30-40/50</b> |
| – <b>MCm 30/70</b> | – <b>MC 30-40/70</b>       |

### CHARACTERISTIC CURVES AND PERFORMANCE DATA

50 Hz n= 2900 min<sup>-1</sup>

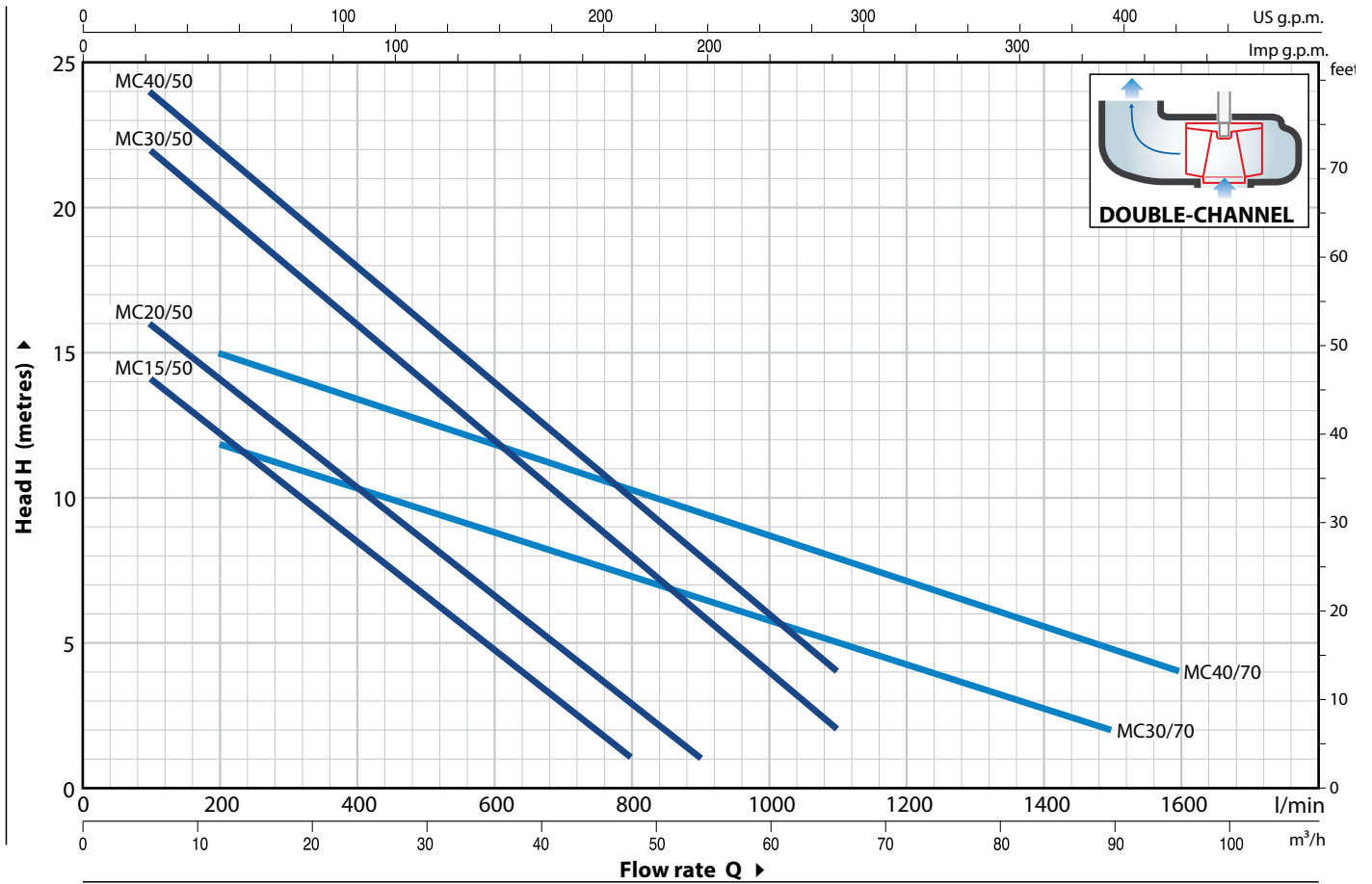

MODEL		POWER (P <sub>2</sub> )		Q	H metres																	
Single-phase	Three-phase	kW	HP		m <sup>3</sup> /h	0	6	12	18	24	30	36	42	48	54	60	66	72	90	96		
				l/min	0	100	200	300	400	500	600	700	800	900	1000	1100	1200	1500	1600			
MCm 15/50	MC 15/50	1.1	1.5	H metres	16	14	12.5	10.5	8.5	6.5	4.5	3	1									
MCm 20/50	MC 20/50	1.5	2		18	16	14	12.5	10.5	8.5	6.5	5	3	1								
MCm 30/50	MC 30/50	2.2	3		24	22	20	18	16	14	12	10	8	6	4	2						
-	MC 40/50	3	4		25	24	22	20	18	16	14	12	10	8	6	4						
MCm 30/70	MC 30/70	2.2	3		13	-	12	11	10.5	9.7	9	8	7.5	6.5	6	5	4.5	2				
-	MC 40/70	3	4		17	-	15	14	13.5	12.5	12	11	10.5	9.5	8.5	8	7	4.8	4			

Q = Flow rate H = Total manometric head

Tolerance of characteristic curves in compliance with EN ISO 9906 Grade 3B.

  = Stocked in Australia

Other models available upon request with 6 to 8 weeks lead time.

## POS. COMPONENT CONSTRUCTION CHARACTERISTICS

1	<b>PUMP BODY</b>	Cast iron with threaded port in compliance with ISO 228/1
2	<b>BASE</b>	Stainless steel AISI 304
3	<b>IMPELLER</b>	Precision cast stainless steel AISI 304 DOUBLE-CHANNEL type
4	<b>MOTOR CASING</b>	Cast iron
5	<b>MOTOR CASING PLATE</b>	Cast iron
6	<b>MOTOR SHAFT</b>	Stainless steel AISI 431

### 7 TWO MECHANICAL SEALS SEPARATED BY AN OIL CHAMBER

Seal Model	Shaft Diameter	Position	Materials		
			Stationary ring	Rotational ring	Elastomer
STA-20	Ø 20 mm	Motor side	Ceramic	Graphite	NBR
STA-19	Ø 19 mm	Pump side	Silicon carbide	Silicon carbide	NBR

### 8 BEARINGS 6304 ZZ - C3 / 6304 ZZ - C3

### 9 CAPACITOR

Pump	Capacitance
Single-phase	(230 V or 240 V)
MCm 15/50	31.5 µF 450 VL
MCm 20/50	50 µF 450 VL
MCm 30/50	60 µF 450 VL
MCm 30/70	60 µF 450 VL

### 10 ELECTRIC MOTOR

**MCm 15-20:** single-phase 230 V - 50 Hz with thermal overload protector incorporated into the winding

⇒ **MCm 30:** single-phase 230 V - 50 Hz with thermal overload protector incorporated into the winding to be connected to the control box

⇒ **MC:** three-phase 400 V - 50 Hz. with thermal overload protector incorporated into the winding to be connected to the control box (supplied on demand)

- Insulation: class F
- Protection: IP X8

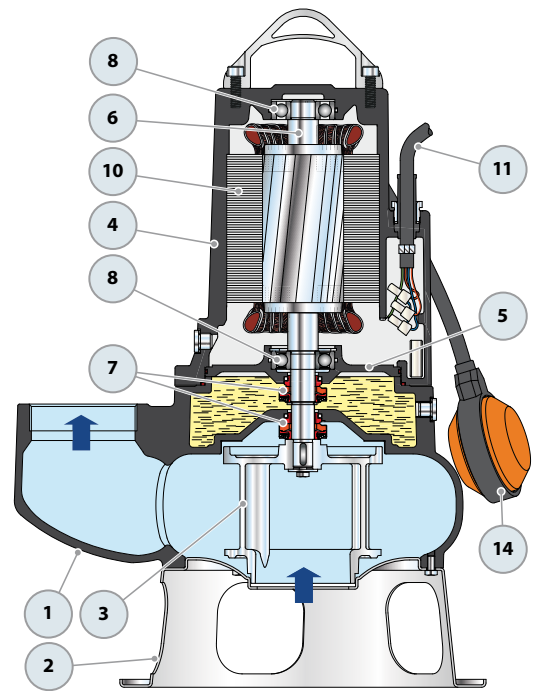

### 11 POWER CABLE

10 metres long "H07 RN-F" cable

### 12 CONTROL BOX for MCm 15-20

(only for single-phase versions)

Complete with capacitor and manual reset motor protector

### 13 CONTROL BOX for MCm 30

(only for single-phase versions)

QES 300 MONO series

### 14 FLOAT SWITCH

(only for single-phase versions)

Standard features

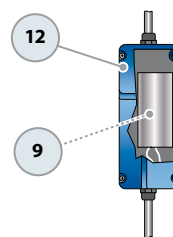

Control box for MCm 15-20 (only for single-phase versions)

Standard features

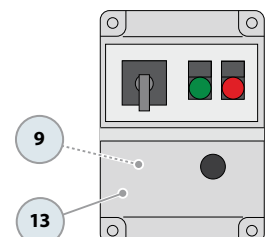

Control box for MCm 30 (only for single-phase versions)

## DIMENSIONS AND WEIGHT

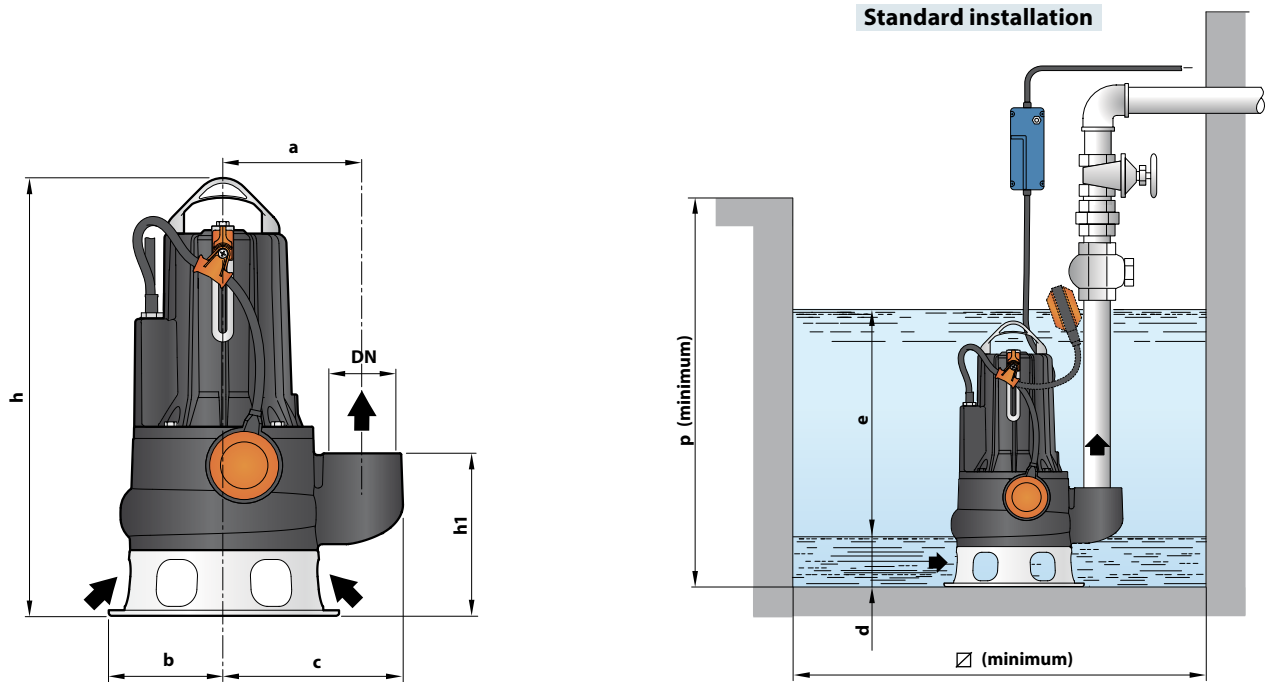

MODEL		PORT DN	Passage of solids	DIMENSIONS mm										kg	
Single-phase	Three-phase			a	b	c	h	h1	d	e	p	Ø	1~	3~	
MCm 15/50	MC 15/50	2½"	Ø 50 mm	162	135	210	520	191	75	variable	800	800	37.8	36.2	
MCm 20/50	MC 20/50						517						38.6	37.2	
MCm 30/50	MC 30/50						530						43.0	39.0	
-	MC 40/50						-						-	43.4	
MCm 30/70	MC 30/70	3"	Ø 70 mm	180	150	237	577/563	233	85				45.4	42.2	
-	MC 40/70						577						-	46.3	

## ABSORPTION

MODEL	VOLTAGE	
	230 V	240 V
MCm 15/50	9.0 A	9.0 A
MCm 20/50	10.5 A	10.0 A
MCm 30/50	15.2 A	15.2 A
MCm 30/70	15.2 A	15.2 A

MODEL	VOLTAGE		
	230-240 V	400-415 V	690-720 V
MC 15/50	6.1 A	3.5 A	2.0 A
MC 20/50	7.4 A	4.3 A	2.5 A
MC 30/50	9.9 A	5.7 A	3.3 A
MC 40/50	13.5 A	7.8 A	4.5 A
MC 30/70	10.2 A	5.9 A	3.4 A
MC 40/70	13.5 A	7.8 A	4.5 A

## PALLETIZATION

MODEL		GROUPAGE n. pumps
Single-phase	Three-phase	
MCm 15/50	MC 15/50	16
MCm 20/50	MC 20/50	16
MCm 30/50	MC 30/50	16
-	MC 40/50	16
MCm 30/70	MC 30/70	12
-	MC 40/70	12