

SUBMERSIBLE PUMPS

Drainage & Vortex Submersibles

HDS SERIES

HDS-25



APPLICATION

HDS Series Stainless Steel Submersible pumps for stormwater pits, lift wells, plant room sumps and general water transfer for water tanks and swimming pools. The HDS Series sump pumps have a double mechanical seal to ensure long life and durability capable of pumping water with 10mm suspended solids.

FEATURES

- Pump Body / Motor Casing: AISI 304 Stainless steel
- Impeller: AISI 304 Stainless Steel
- Motor Shaft: AISI 304 Stainless Steel
- Double Mechanical Seal: Upper – Carbon Ceramic/NBR, Lower – SiC/SiC/NBR closed in oil chamber
- Max. Operating Depth: 10m
- Max. Fluid Temp: 40c
- Max. Suspended Solids: 10mm
- Two pole Induction Motor
- 50 Hz 1Ph 240 Volt
- Protection IPX8
- Insulation Class F
- Thermal Overload Protection
- 10m Power Cable
- 40mm F Top Discharge

PERFORMANCE

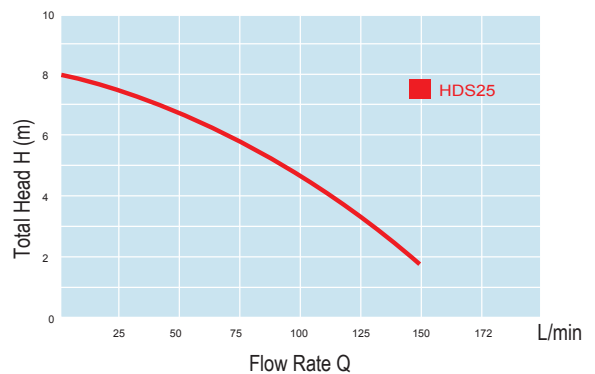



HDS-75



HDS-110

PERFORMANCE

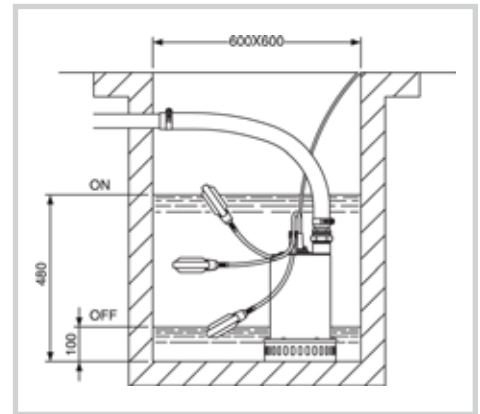
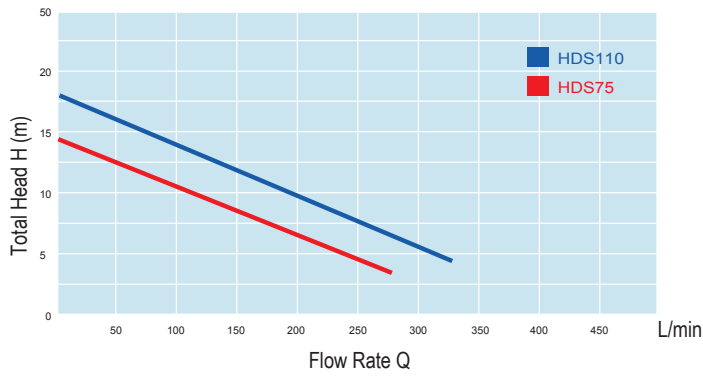

TECHNICAL DATA

Model	Power (KW)	Amps (A)	Max. Flow	Max. Head	Impeller	Outlet
HDS25	0.25	1.9	150 L/min	7.5m	Vortex	32mm
HDS75	0.75	5.28	275 L/min	15m	Vortex	40mm
HDS110	1.1	7.0	330 L/min	18m	Vortex	40mm