

WATER SUPPLY & PRESSURE PUMPS

Shallow Well Pumps

CAB SERIES

AVAILABLE WITH PRESSURE CONTROLLER



EURO RANGE

APPLICATION

Self-priming centrifugal pump for water supplies (even if mixed with air) in small and medium house hold and civil systems; when connected to pressure tanks, an automatic pressurisation system comes.

CONSTRUCTION FEATURES

Pump body	Cast iron
Motor bracket	Cast iron
Impeller	Noryl® or brass
Mechanical seal	Ceramic-graphite
Motor shaft	Stainless steel AISI 303 hydraulic side,
Liquid temperature	0 - 50 °C
Operating pressure	Max 8 bar

MOTOR

2 Pole induction motor	3~ 240/400V-50Hz, 1~240V 50Hz, With thermal protection
Insulation class	F
Protection degree	IP44

TECHNICAL DATA

Type		P2		P1 (kW)		Ampere		Q (m³/h - l/min)									
1~	3~					1~	3~	0	0.6	1.2	1.8	2.4	3	3.6	3.8		
						1x230V	3x400V	0	10	20	30	40	50	60	60.3		
						50 Hz	50 Hz	H (m)									
CAB150	CABT150	1.5	1.1	1.74	1.68	7.9	3.3	61	56.5	54	48	41	32	-	-	-	
CAB200	CABT200	2	1.5	2.22	2.1	10.3	3.9	62.5	59.5	58	54	49	42.5	34	-	-	
CAB300	CABT300	3	2.2	2.65	2.5	11.8	4.9	64.5	62	60.5	57	52.5	47	42	35	32	

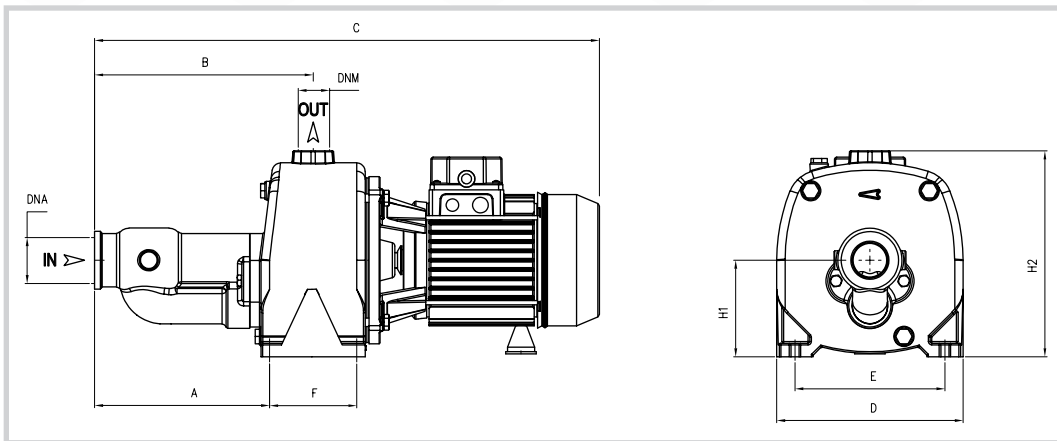
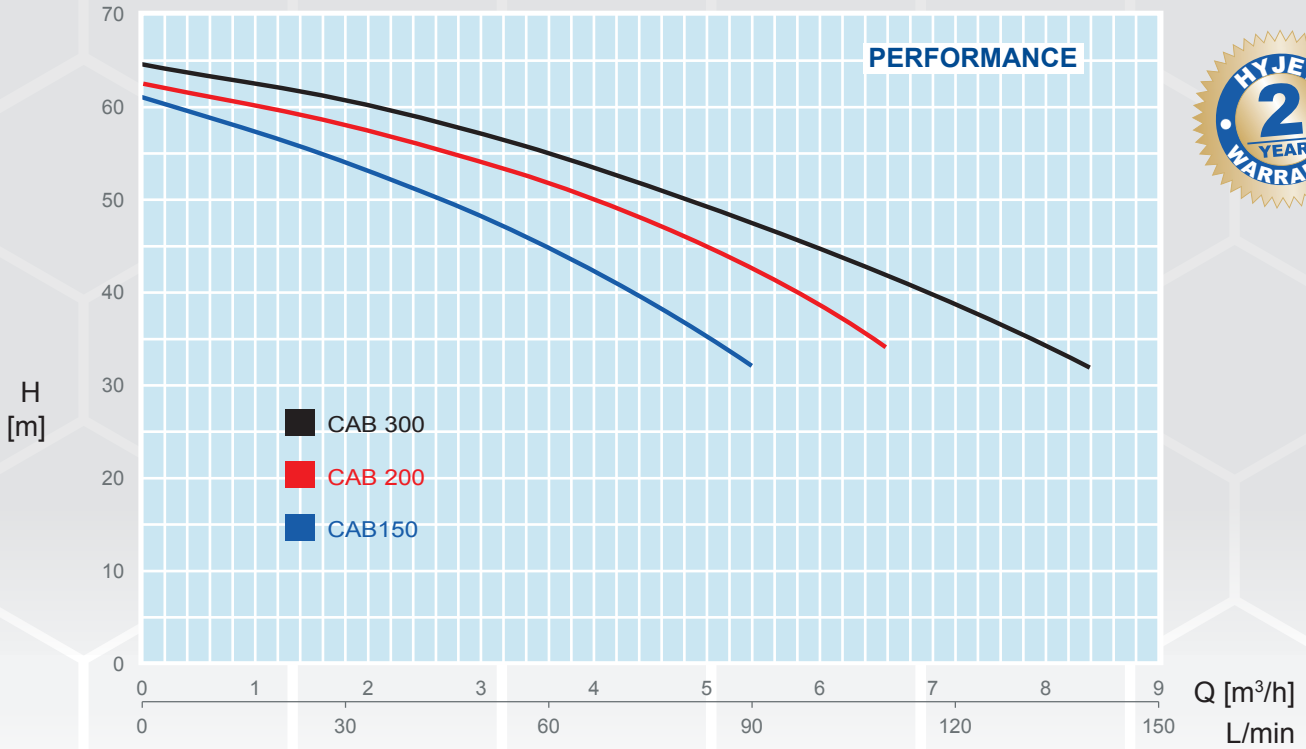

DIMENSIONS

Type	Dimensions (mm)										Weight			
	A	B	C	D	E	F	H1	H2	DNA	DNM	I	L	M	Kg
CAB150	204	257	596	220	177	150	112	240	1"1/2G	1"G	610	235	275	30
CAB200	204	257	596	220	177	105	112	240	1"1/2G	1"G	610	235	275	30.5
CAB300	204	257	596	220	177	105	112	240	1"1/2G	1"G	610	235	275	31.5

MODEL RANGE

Code	Description
CAB150-1	HYJET 1.1 KW 240V 90 L/min Cast Iron Shallow Well Pump with 2.5m Cable and 3 Pin Plug
CAB200-1	HYJET 1.5 KW 240V 120 L/min Cast Iron Shallow Well Pump with 2.5m Cable and 3 Pin Plug
CAB300-1	HYJET 2.2 KW 240V 140 L/min Cast Iron Shallow Well Pump with 2.5m Cable and 3 Pin Plug
CAB300-3	HYJET 2.2 KW 415V 140 L/min Cast Iron Shallow Well Pump with 2.5m Cable
CAB150-1-PC	HYJET 1.1 KW 240V 90 L/min Cast Iron Shallow Well Pump with HPC22 Pressure Controller
CAB200-1-PC	HYJET 1.5 KW 240V 120 L/min Cast Iron Shallow Well Pump with HPC22 Pressure Controller