

# WATER SUPPLY & PRESSURE PUMPS

## Deep Well Pumps

### AP SERIES

AVAILABLE WITH PRESSURE CONTROLLER



**EURO RANGE**



### APPLICATION

Self-priming centrifugal pump with external ejector (convertible) 2" and 4"; for water supplies (even if mixed with air) in small household systems, when connected to pressure tanks, an automatic pressurisation system comes.

### CONSTRUCTION FEATURES

<b>Pump body</b>	Cast iron
<b>Motor bracket</b>	Cast iron or aluminum (AP 75÷100), Cast iron (AP 150÷200)
<b>Impeller</b>	Noryl® or brass
<b>Mechanical seal</b>	Ceramic-graphite
<b>Motor shaft</b>	Stainless steel AISI 416 (AP 75÷100), AISI 303 hydraulic side (AP 150÷200) 0 - 50 °C
<b>Liquid temperature</b>	AISI 303 hydraulic side (AP 150÷200) 0 - 50 °C
<b>Operating pressure</b>	Max 8 bar

### MOTOR

<b>2 Pole induction motor</b>	3~ 240/400V-50Hz, With thermal protection
<b>Insulation class</b>	F
<b>Protection degree</b>	IP44

### TECHNICAL DATA

Type		P2		P1 (kW)		Ampere		Ejector type	Suction depth m	Q (m³/h - l/min)										
1~	3~	(HP)	(kW)	1~	3~	1~	3~			0.18	0.36	0.6	0.91	.2	1.51	.8	2.133		.6	
						1x230V 50 Hz	3x400V 50 Hz			H (m)										
AP100	APT100	1	0.74	1.02	1.05	4.7	2.3		25	30	25	20	14	11	-	-	-	-	-	
								P 30	30	14	8	-	-	-	-	-	-	-	-	-
									35	12	4	-	-	-	-	-	-	-	-	-
AP150	APT150	1.5	1.1	1.65	1.65	8.2	3		35	-	-	-	49	41	20	-	-	-	-	
								P 30	40	-	-	48	40	-	-	-	-	-	-	
									50	-	49	43	20	-	-	-	-	-	-	

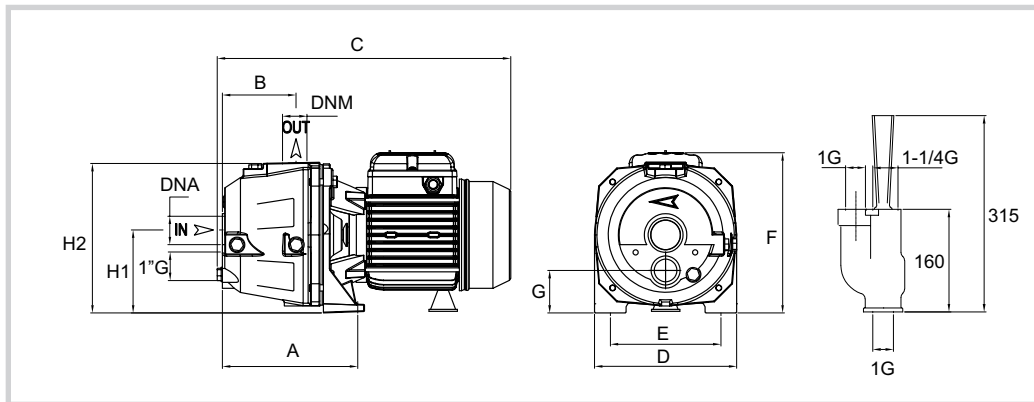
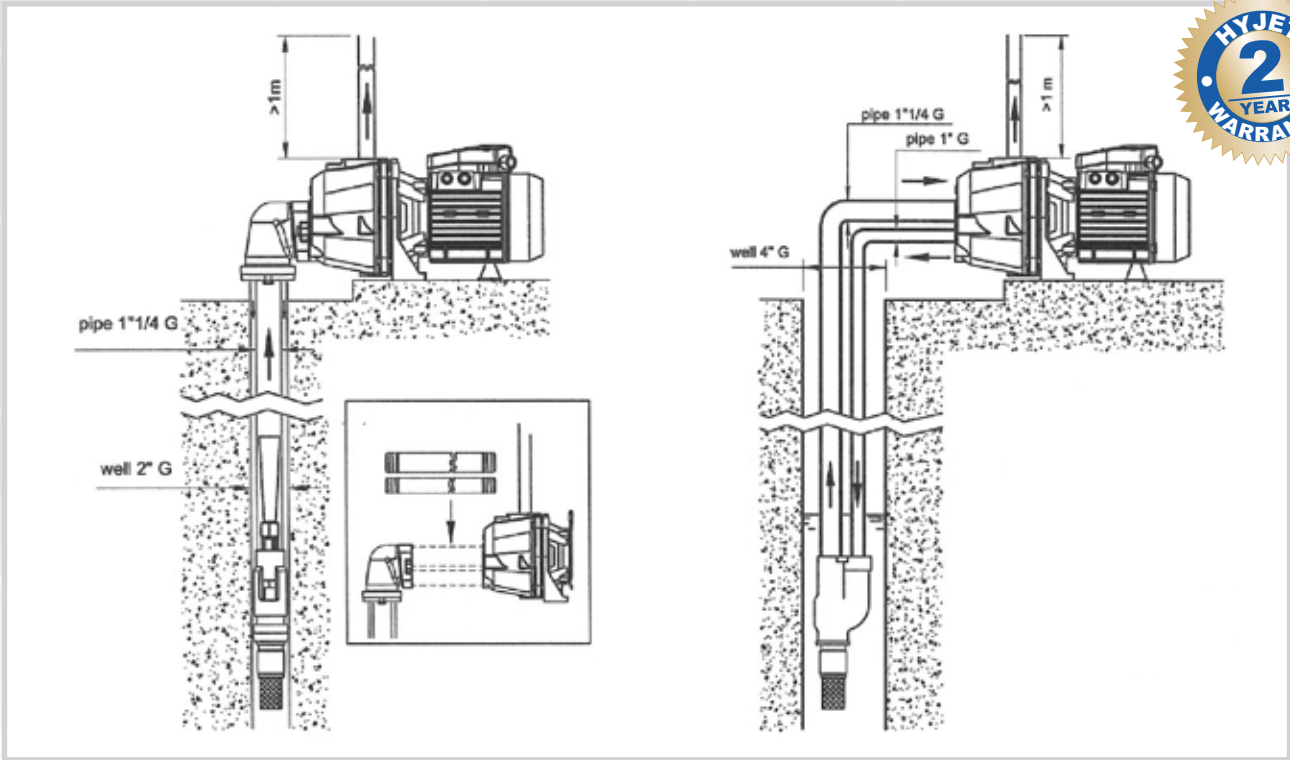

## DIMENSIONS

Type	Dimensions (mm)														
	A	B	C	D	E	F	G	H1	H2	DNA	DNM	I	L	M	
AP100	168	82	360	180	140	195	52	97	188	1 1/4G	1 G	440	200	225	18
AP150	125	74	415	220	177	230	60	112	240	1 1/4G	1 G	525	230	280	28.5

## MODEL RANGE

Code	Description
AP100-4-1	HYJET 0.74 KW 240V 2 m3/h Cast Iron P30 Deep Well Pump with 2.5m Cable and 3 Pin Plug
AP150-4-1	HYJET 1.1 KW 240V 4 m3/h Cast Iron P30 Deep Well Pump with 2.5m Cable and 3 Pin Plug
AP100-4-1-PC	HYJET 0.74 KW 240V 2 m3/h Cast Iron P30 Deep Well Pump with 2.5m Cable and 3 Pin Plug with HPC22 Pressure Controller
AP150-4-1-PC	HYJET 1.1 KW 240V 4 m3/h Cast Iron P30 Deep Well Pump with 2.5m Cable and 3 Pin Plug with HPC22 Pressure Controller