

HEAVY DUTY WASTEWATER SUBMERSIBLE PUMPS

PRODUCT OVERVIEW

HYJETS new generation of drainage and wastewater submersible pumps are developed with the highest quality and professional technology.

The HW Series are available in a variety of non-clogging impeller designs to meet any drainage and wastewater application.

PUMP

- Max. immersion depth: 5m
- Max. liquid temperature: +40oC
- Liquid PH value: 4-10 3 3
- Max. liquid density: 1.2x10 kg/m
- Power Range: 0.37kW - 4kW

IDENTIFICATION CODES

HWV50-037-1A

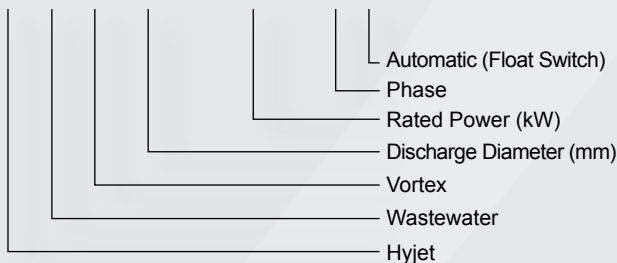

REPLACEABLE CABLE DESIGN

The unique cable design reduces the maintenance cost to a minimum. If the cable is damaged, either by a grease attack or corrosion from general wear and tear, it can be easily removed and replaced without dismantling the pump. Cable sleeve is epoxy resin filled for reliability.

A VARIETY OF IMPELLERS ARE AVAILABLE FOR DIFFERENT WASTEWATER SOLUTIONS:

G TYPE IMPELLER

Semi-open impeller with grinder system which grinds foreign material to avoid solids clogging. It's suitable for long distance delivery of sewage and wastewater applications.



E TYPE IMPELLER

Enclosed Channel impeller, high efficiency and non-clogging design, is suitable for general wastewater and drainage.



V TYPE IMPELLER

Semi-open Vortex impeller, allowing long fibrous materials and other solid waste to pass through without contact with the impeller.



HW SERIES

GUIDE RAIL SYSTEMS

Suitable for pumps with flange conforming SO7005-92 standard. Where the sewage contains dirt, cloth, fibre, etc.

INCLUDES

- Guide hook
 - Flange connector
 - Upper guide support
 - Bolts and lock washers
- (Foundation bolts and guide pipes are not included)

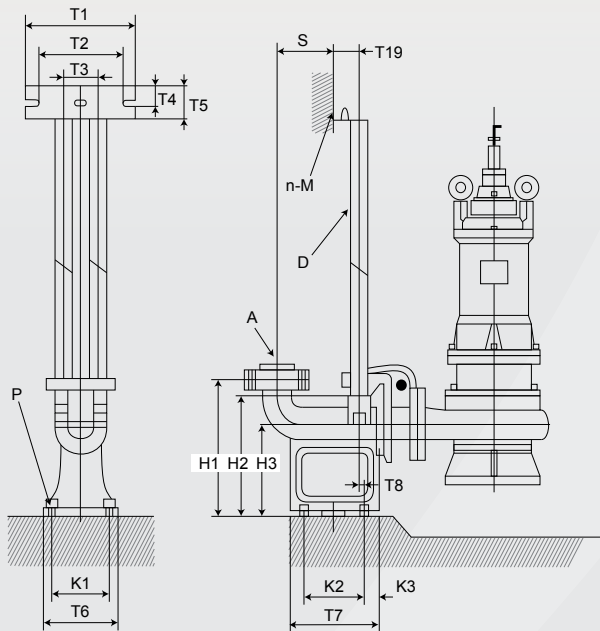

Model	T1	T2	T3	T4	T5	T6	T7	T8	T9	K1	K2	K3	S	H1	H2	H3	D	n-M	P	A
HGRK50-50	288	185	70	25	63	160	200	10	50	120	120	40	125	250	203	170	25	2=M10X40	M16	Ø110/4-Ø14
HGRK65-65	288	185	80	25	63	190	220	10	60	120	120	40	130	250	203	175	32	2=M10X40	M16	Ø130/4-Ø14
HGRK80-80	288	185	80	25	63	220	250	15	60	170	170	40	165	290	242	192	32	2=M10X40	M16	Ø150/4-Ø18

GRINDER PUMPS

HWG32/HWG50



SUBMERSIBLE PUMPS

APPLICATION

- Heavy duty grinder pump for pumping sewage
- Ideal for pumping sewage and wastewater in domestic, commercial and industrial applications

FEATURES

- Semi-open impeller design with hardened stainless steel grinding system
- The large-diameter impeller generates a high pressure, and the grinding system grinds solids into small pieces, which can be drained without clogging the pipes
- Heavy duty HT200 cast iron construction
- Stainless steel shaft
- Guide rail kits available for all models
- Thermal overload protection

WORKING CONDITIONS

- Liquid Temperature: 0- 40oC (32-104oF)
- Max Immersion Depth: 5m

MOTOR

- Frequency/Pole number: 50Hz/2
- Insulation Class: F
- Protection Class: IPX8
- Heavy Duty Ball Bearings
- Double Silicon/Carbon Mechanical Seals

TECHNICAL DATA

Model	Power kW (HP)	Discharge mm (inch)	Phase	Rated Flow (m ³ /h)	Rated Head	Solid Passage (mm)
HWG32-11-1	1.1 (1.5)	32 (1 1/4")	1	3.6	17	-
HWG32-11-1A	1.1 (1.5)	32 (1 1/4")	1	3.6	17	-
HWG32-11-3	1.1 (1.5)	32 (1 1/4")	3	3.6	17	-
HWG32-15-1	1.5 (2)	32 (1 1/4")	1	3.6	23	-
HWG32-15-3	1.5 (2)	32 (1 1/4")	3	3.6	23	-
HWG32-22-1	1.5 (2)	32 (1 1/4")	1	3.6	30	-
HWG32-22-3	1.5 (2)	32 (1 1/4")	3	3.6	30	-
HWG50-22-3	2.2 (3)	50 (2")	3	12	19	-
HWG50-30-3	3 (4)	50 (2")	3	12	22	-
HWG50-40-3	4 (5.5)	50 (2")	3	12	30	-

HWG SERIES

SUBMERSIBLE PUMPS

PERFORMANCE CURVE

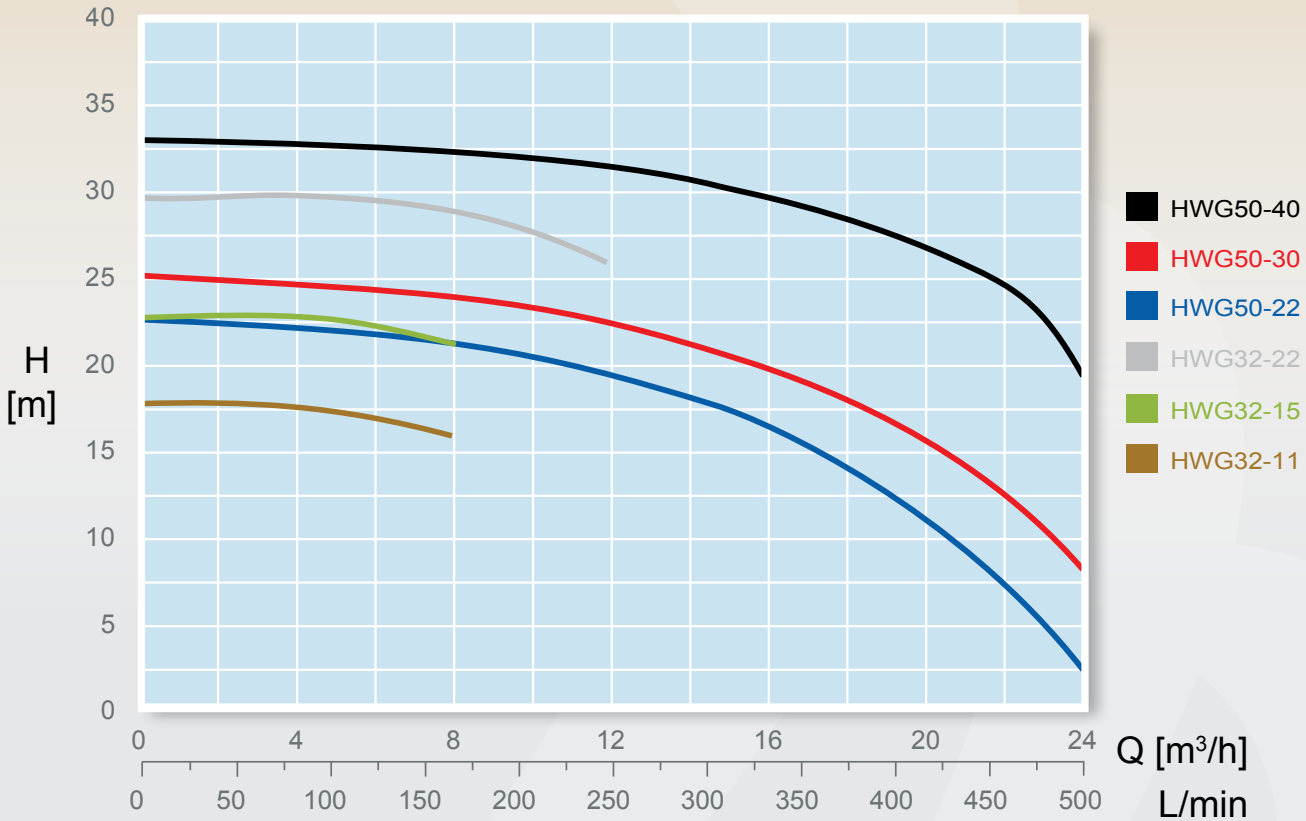

DIMENSIONS

Model	Phase	Ø	L1	L2	L3	L4	H	H1	D	D1	D2	M
HWG32-11-1	1		231	191	96	140	533	73	32	90	14	16
HWG32-11-1A	1		231	191	96	140	533	73	32	90	14	16
HWG32-11-3	3		231	191	96	140	533	73	32	90	14	16
HWG32-15-1	1		231	191	96	140	598	73	32	90	14	16
HWG32-15-3	3		231	191	96	140	557	73	32	90	14	16
HWG32-22-1	1		231	191	96	140	598	73	32	90	14	16
HWG32-22-3	3		231	191	96	140	557	73	32	90	14	16
HWG50-22-3	3		243	212	106	145	560	73	50	110	14	16
HWG50-30-3	3		243	212	106	145	586	73	50	110	14	16
HWG50-40-3	3		243	212	106	145	586	73	50	110	14	16

