



HV SERIES



HV750

APPLICATION

- Stormwater
- Septic treatment systems
- Waste / Greywater transfer
- Sump draining

FEATURES

- Stainless steel motor and pump shaft
- Double mechanical seal with oil barrier and lip seal
- Soft solids handling up to 15mm
- 10m power cable
- Thermal overload protection

CONSTRUCTION

- Pump body: Cast iron
- Motor shaft: Stainless steel AISI 304
- Impeller: Cast iron
- Mechanical seal: Double Ceramic – Graphite + Oil barrier
- Motor IP68 – Insulation class B
- Electric power cable HO5RN 10m with 3 pin

VORTEX SUBMERSIBLE PUMP



SUBMERSIBLE PUMPS

PERFORMANCE CURVE

2900 rpm

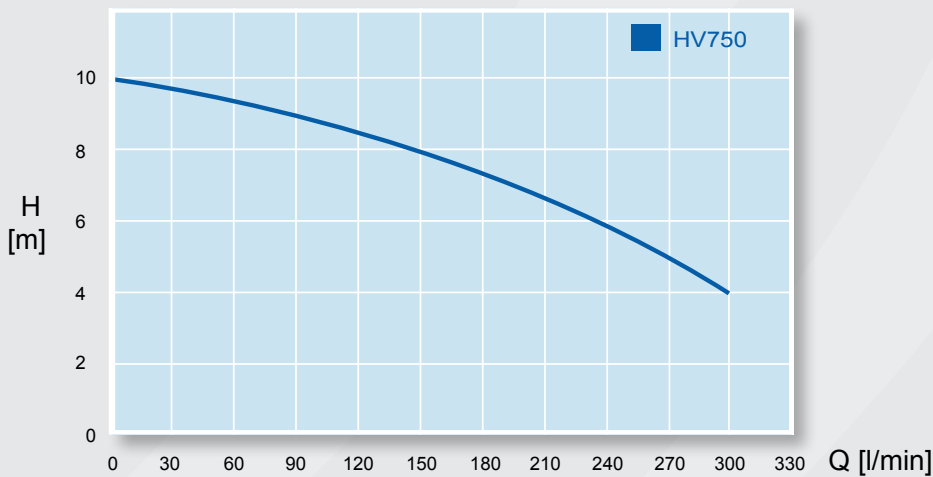

DIMENSIONS

Pump Model	Size (mm)		DN1	G.W (KG)
	H	L		
HV750	490	220	50F	20.7

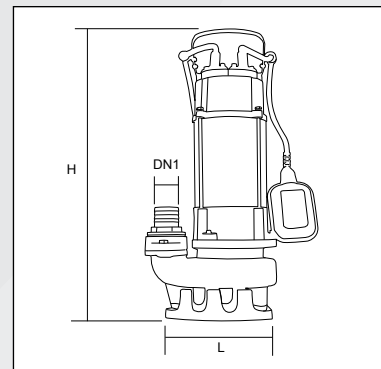

TECHNICAL DATA

Pump Model	Power (P2) (kW)	Amps (A)	Max. FLOW (L/min)	Max. HEAD (m)	Cable (m)	Pump Style	Outlet	Solids Passage (mm)
HV750	0.75	5.5	300	10	10	Vortex	2"	25