

Zenox Undersink Sullage Units



- Robust, high quality, dirty water pump
- Ideal for remote kitchens, basements, etc.
- Quality construction – Made in Italy
- Complete with check valve, pipework and connection ports

SPECIFICATION:

- **BCm 15/50-1A** 0.75 kW Double Channel Pumps for dirty water
- 11 metres max head
- 500 litres per minute max flow rate
- Inbuilt non-return valve
- 100 litre capacity
- 40 mm outlet
- 50/100 mm inlet
- 10 metre cable H07 RN-F

FEATURES:

- Tough, robust, easy-clean poly construction
- Fully sealed lid to prevent odours

- Anti-fouling float positioning
- Complete package – easy to install
- Pump will withstand 90°C water for up to 3 minute intervals
- High Level Alarm option available
- Water stop safety option available
- Dishwasher stop option available

PUMP PERFORMANCE:

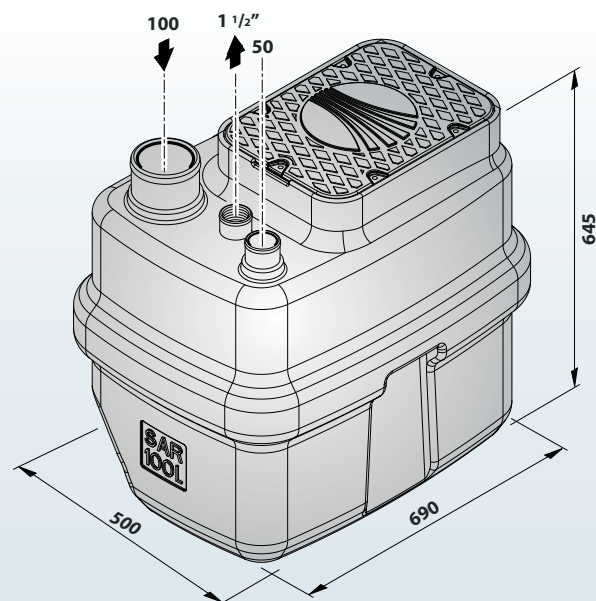
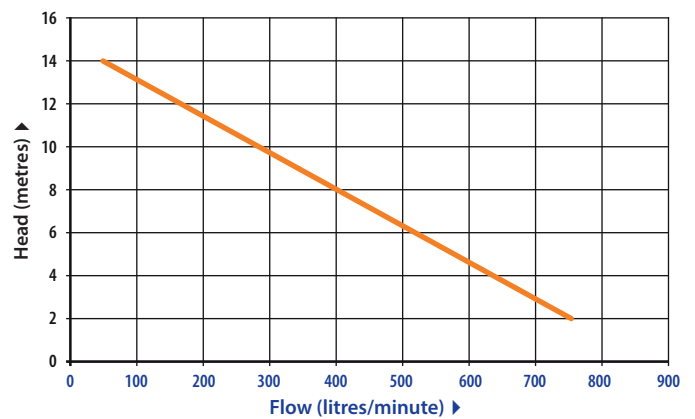

Zenox Pumps

Zenox Pumps reserves the right to change product specifications

