

## Zenox High Head Sewage Grinder Pumps



- Twin-stage, extra high head grinder pump
- Ideal for high static heads and pressure sewer systems
- Unmatched performance, double output pressure
- Suited to industrial, commercial and residential applications

### Two Models Available:

**HHG-150-1** 240 volt, 1.5 kW, Manual

**HHG-150-3** 415 volt, 1.5 kW, Manual

### SPECIFICATION:

- 66 metres max head
- 1.7 litres per second max flow rate
- 1.5 kW motor
- Weight 42 kg
- 32 mm vertical discharge

### FEATURES:

- Heavy duty cast iron construction

- Hardened 440 SST (56-60 RockWell) shredding ring and grinding impeller
- 11,500 cuts/second, 690,000 cuts/minute
- Dual full mechanical seals (silicon/carbide)
- Triple sealed cable design
- Suit guide rail kit model HHG-GR

### PUMP PERFORMANCE:

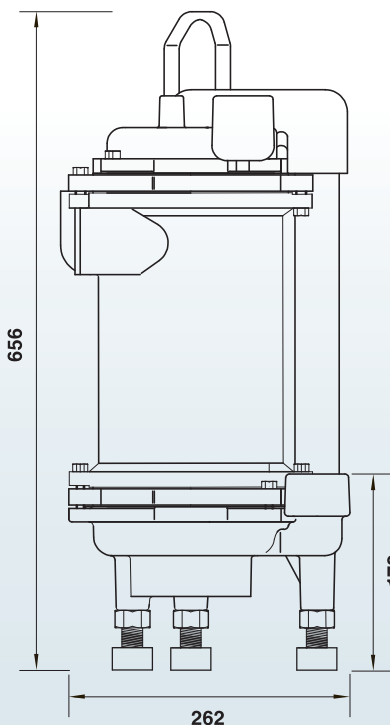
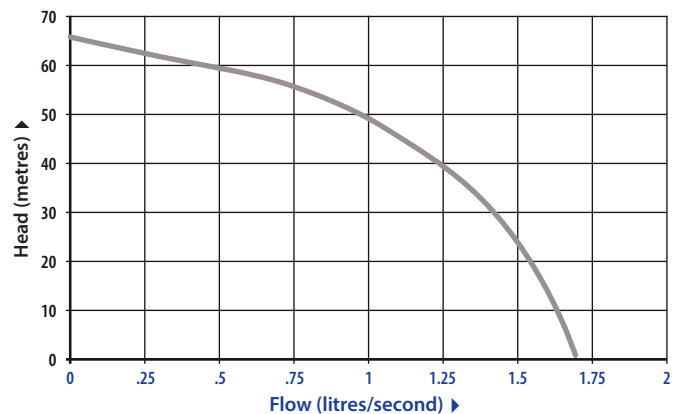

Zenox Pumps

Zenox Pumps reserves the right to change product specifications

