

Zenox Submersible Sewage Grinder Pump



- Heavy duty grinder pump for pumping sewage
- Hardened cutters for maximum grinding action
- Suited to industrial, commercial and residential applications

SPECIFICATION:

- 42 metres max head
- 5.6 litres per second max flow rate
- 3.7 kW, 415 volt motor
- Weight 82 kg

FEATURES:

- All cast iron construction
- Hard chrome steel grinding mechanism

- Double mechanical seal (SiC/SiC + CA/CE)
- Double cable entry seal – with epoxy vapour seal
- Suits guide rail kit model ZGRK 32/50

PUMP PERFORMANCE:

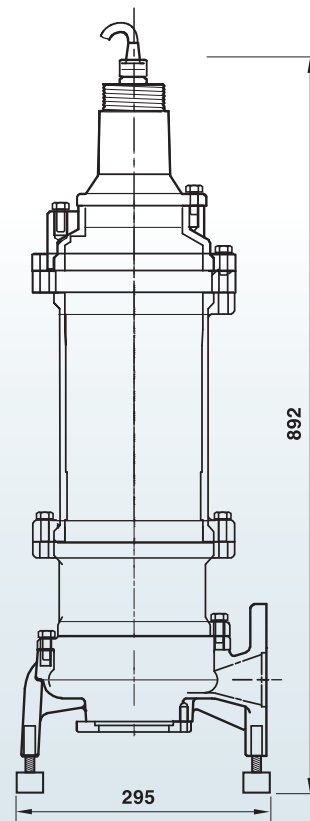
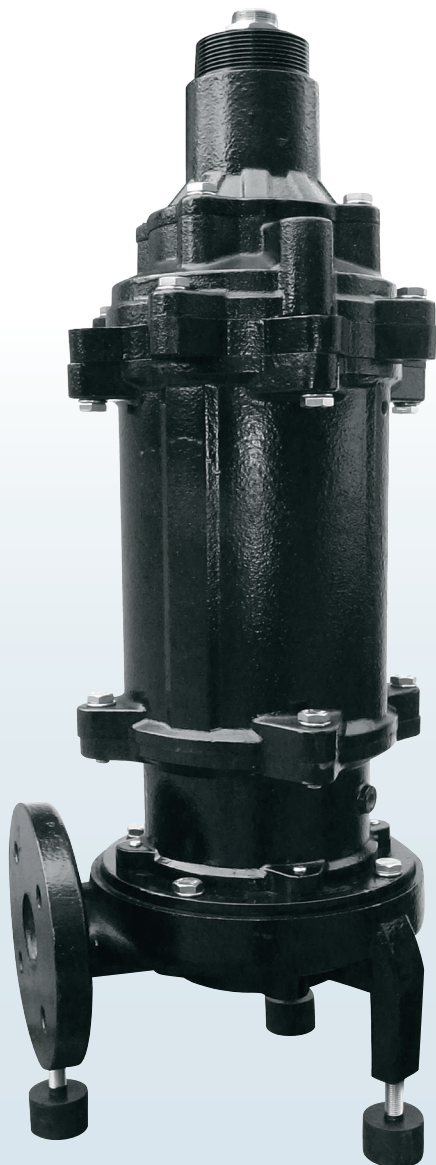
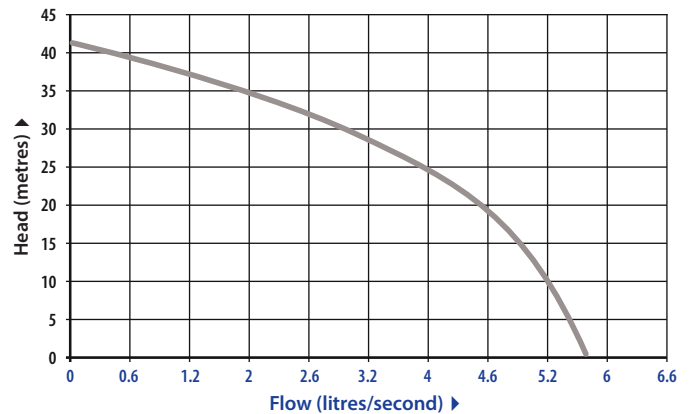

Zenox Pumps

Zenox Pumps reserves the right to change product specifications

