

Zenox Puddle Sucker Drainage Pump



- Robust, high quality, emergency pump
- Applications where maximum drainage required

SPECIFICATION:

- 7.0 metres max head
- 120 litres per minute max flow rate
- 0.25 kW, submersible asynchronous 240 volt motor for continuous duty
- Suction grid inlet
- 32 mm outlet
- Weight 5.0 kg
- 10 metre cable H07 RN-F

FEATURES:

- Stainless steel shaft
- Glass filled technopolymer pump body
- Noryl FE1520PW impeller
- Mech seal, ceramic – graphite – NBR, plus inner lip seal in oil barrier chamber

- Stainless steel motor support
- Thermal overload protection
- Robust construction, very resistant to impact and corrosion
- Will drain down to a level of 2 mm

PUMP PERFORMANCE:

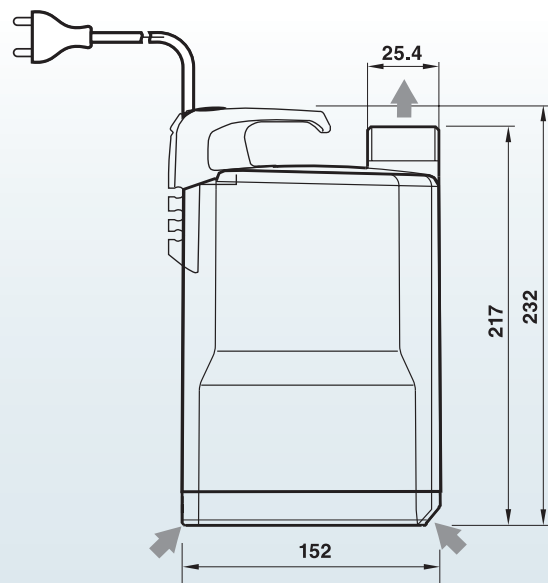
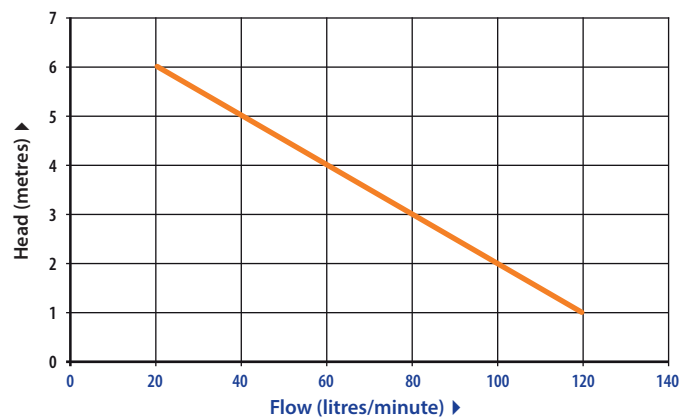

Zenox Pumps

Zenox Pumps reserves the right to change product specifications

