

## Zenox Automatic Submersible Vortex Pump



- Robust, high quality, dirty water pump
- Drainage of water containing suspended solids
- Emptying of sumps and tanks

### SPECIFICATION:

- 7 metres max head
- 180 litres per minute max flow rate
- 0.37 kW, submersible asynchronous 240 volt motor for continuous duty
- Vortex inlet system
- 32 mm outlet
- Weight 5.2 kg
- 10 metre cable H07 RN-F

### FEATURES:

- Stainless steel motor shaft
- Technopolymer pump body
- Technopolymer impeller - vortex type
- Mech seal, ceramic -graphite – NBR, plus inner lip seal in oil barrier chamber

- Stainless steel motor casing
- Thermal overload protection
- Robust construction, very reliable and will withstand liquid temperatures up to 40°C
- Will withstand 90°C liquid temperatures in 3 minute intervals
- Passage of solid bodies up to 20 mm

### PUMP PERFORMANCE:

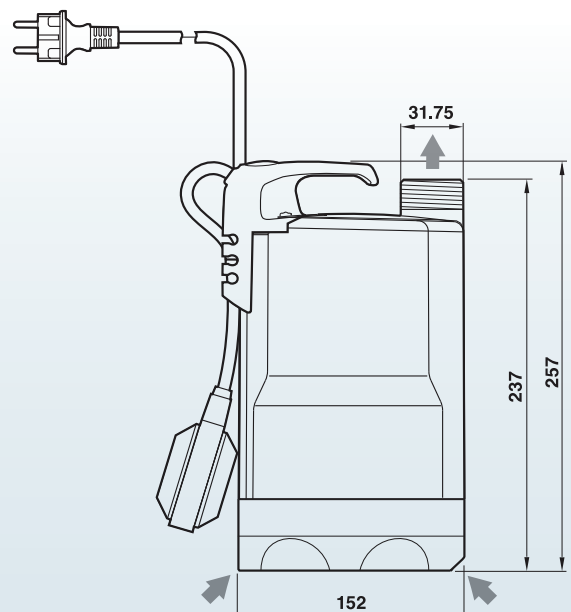
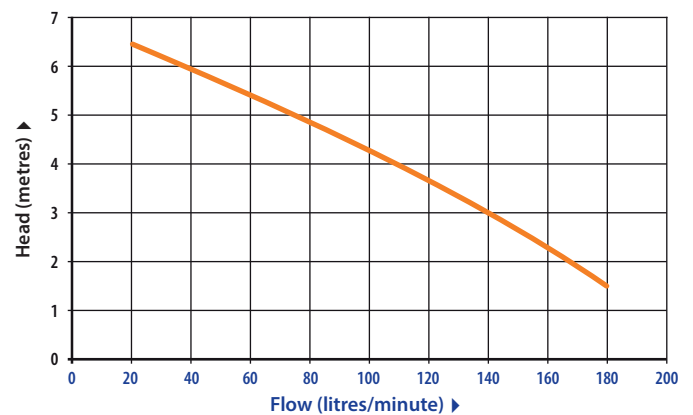

Zenox Pumps

Zenox Pumps reserves the right to change product specifications

