

## Zenox Horizontal Multistage Pressure System Pump



- High pressure, large flow applications
- Pressurisation and distribution of water
- Irrigation and rainwater recovery systems

### SPECIFICATION:

- 50 metres max head
- 130 litres per minute max flow rate
- 1.1 kW, 240 volt TEFC "quiet" motor suitable for continuous duty
- 32 mm inlet
- 25 mm outlet
- Weight 17.6 kg

### FEATURES:

- Stainless steel shaft
- Stainless steel pump housing
- Long life bearings
- Mech seal, graphite - ceramic - NBR

- Thermal overload protection
- Quiet running, very reliable and low power consumption
- Incorporates heavy duty electronic controller with built in pressure gauge

### PUMP PERFORMANCE:

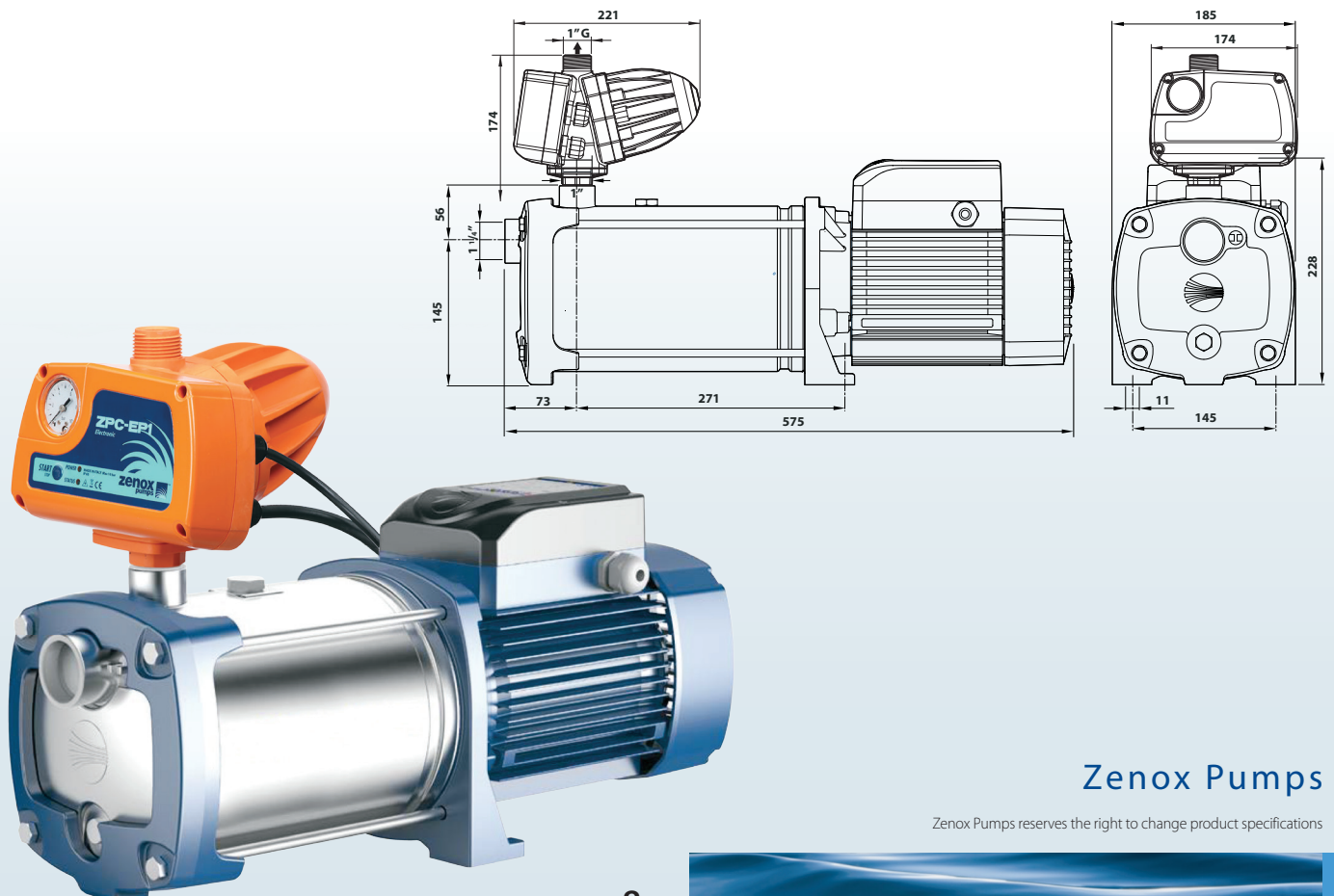
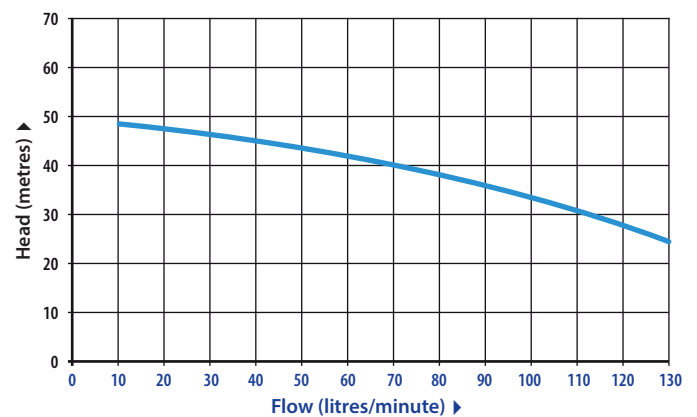

Zenox Pumps

Zenox Pumps reserves the right to change product specifications

